



**COMMONWEALTH OF KENTUCKY
TRANSPORTATION CABINET**
Frankfort, Kentucky 40622
www.transportation.ky.gov/

Matthew G. Bevin
Governor

Greg Thomas
Secretary

November 10, 2016

CALL NO. 303
CONTRACT ID NO. 162316
ADDENDUM # 1

Subject: Larue County, FD05 062 0061 008-011
Letting November 18, 2016

- (1) Revised - Note - Page 9 of 82
- (2) Revised - Typical Section - Pages 27-28 of 82
- (3) Revised - Bid Items - Page 82 of 82

Proposal revisions are available at <http://transportation.ky.gov/Construction-Procurement/>.

If you have any questions, please contact us at 502-564-3500.

Sincerely,

A handwritten signature in cursive script that reads "Rachel Mills".

Rachel Mills, P.E.
Director
Division of Construction Procurement

RM:ks
Enclosures



An Equal Opportunity Employer M/F/D

SURFACING AREAS

The Department estimates the mainline surfacing width to be 25' 10" feet.

The Department estimates the total mainline area to be surfaced to be 66,508 square yards.

The Department estimates the shoulder width to be 0 feet on each side.

The Department estimates the total shoulder area to be surfaced to be 0 square yards.

ASPHALT MIXTURE

Unless otherwise noted, the Department estimates the rate of application for all asphalt mixtures to be 110 lbs/sy per inch of depth.

INCIDENTAL SURFACING

The Department has included in the quantities of asphalt mixtures established in the proposal estimated quantities required for resurfacing or surfacing mailbox turnouts, farm field entrances, residential and commercial entrances, curve widening, ramp gores and tapers, and road and street approaches, as applicable. Pave these areas to the limits as shown on Standard Drawing RPM-110-06 or as directed by the Engineer. In the event signal detectors are present in the intersecting streets or roads, pave the crossroads to the right of way limit or back of the signal detector, whichever is the farthest back of the mainline. Surface or resurface these areas as directed by the Engineer. The Department will not measure placing and compacting for separate payment but shall be incidental to the Contract unit price for the asphalt mixtures.

OPTION B

Be advised that the Department will control and accept compaction of asphalt mixtures furnished on this project under OPTION B in accordance with Sections 402 and 403.

**TYPICAL HALF SECTION
LARUE COUNTY
FD05 062 0061 008-011
MICROSURFACE ALTERNATE
MP'S 8.031 TO 10.246**

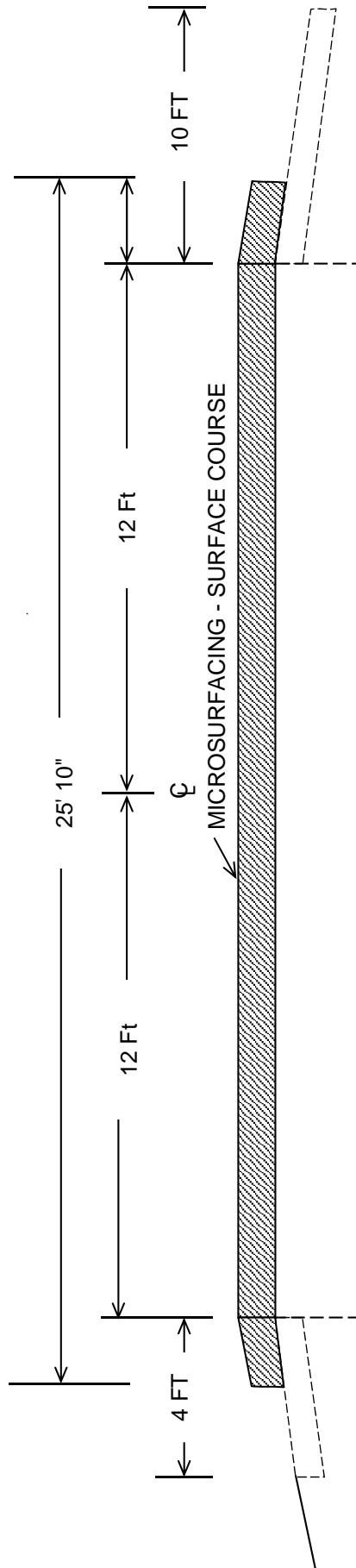

- Note:
- 1). OVERLAY INSIDE TO INSIDE EXISTING SAWED RUMBLE STRIPS
 - 2). OVERLAY ALL LEFT TURN LANES AND MEDIAN CROSSOVERS
 - 3). PAVEMENT MARKERS SHALL BE REMOVED AND THE ALTERNATE SURFACE MATERIAL PLACED TO FILL EXISTING HOLE

**TYPICAL HALF SECTION
LARUE COUNTY
FD05 062 0061 008-011
ULTRATHIN ALTERNATE
MP'S 8.031 TO 10.246**

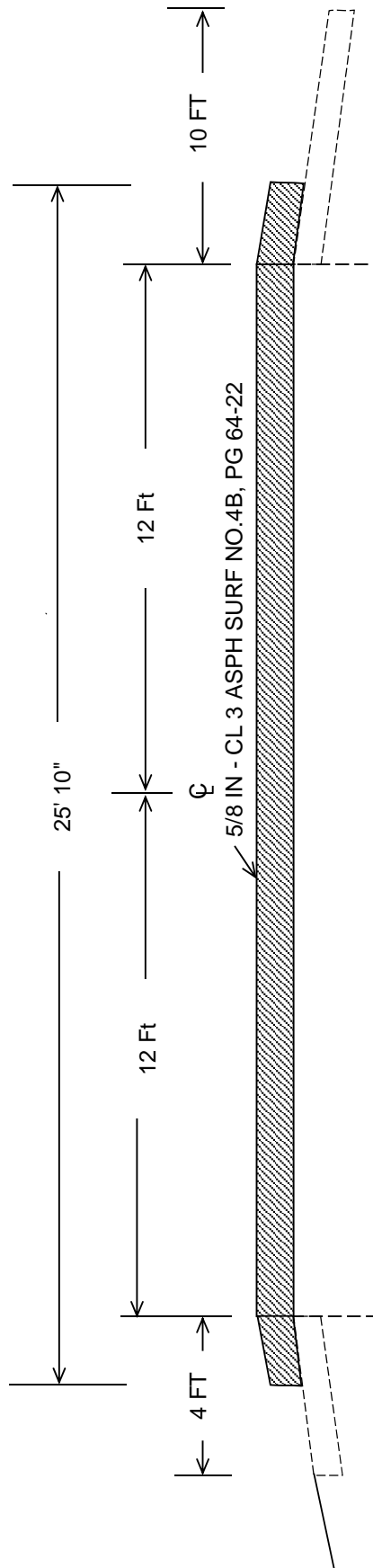

- Note:
- 1). OVERLAY INSIDE TO INSIDE EXISTING SAWED RUMBLE STRIPS
 - 2). OVERLAY ALL LEFT TURN LANES AND MEDIAN CROSSOVERS
 - 3). PAVEMENT MARKERS SHALL BE REMOVED AND THE ALTERNATE SURFACE MATERIAL PLACED TO FILL EXISTING HOLE

PROPOSAL BID ITEMS

REVISED ADDENDUM #1: 11-10-16

162316

Page 1 of 1

Report Date 11/10/16

Section: 0001 - MICROSURFACE

LINE	BID CODE	ALT	DESCRIPTION	QUANTITY	UNIT	UNIT PRIC	FP	AMOUNT
0010	20814EC		MICRO SURFACING-SURFACE COURSE	70,240.00	SQYD		\$	

Section: 0002 - ULTRATHIN

LINE	BID CODE	ALT	DESCRIPTION	QUANTITY	UNIT	UNIT PRIC	FP	AMOUNT
0020	23307EC		CL3 ASPH SURF NO.4B PG64-22 (REVISED: 11-10-16)	2,415.00	TON		\$	

Section: 0003 - ROADWAY

LINE	BID CODE	ALT	DESCRIPTION	QUANTITY	UNIT	UNIT PRIC	FP	AMOUNT
0030	02562		TEMPORARY SIGNS	310.00	SQFT		\$	
0040	02650		MAINTAIN & CONTROL TRAFFIC	1.00	LS		\$	
0050	02671		PORTABLE CHANGEABLE MESSAGE SIGN	2.00	EACH		\$	
0060	02775		ARROW PANEL	2.00	EACH		\$	
0070	06510		PAVE STRIPING-TEMP PAINT-4 IN	1,000.00	LF		\$	
0080	06514		PAVE STRIPING-PERM PAINT-4 IN	52,500.00	LF		\$	
0090	06568		PAVE MARKING-THERMO STOP BAR-24IN	170.00	LF		\$	
0100	06574		PAVE MARKING-THERMO CURV ARROW	6.00	EACH		\$	
0110	06600		REMOVE PAVEMENT MARKER TYPE V	600.00	EACH		\$	
0120	22664EN		WATER BLASTING EXISTING STRIPE	1,020.00	LF		\$	
0130	23875NC		REMOVE THERMOPLASTIC ARROWS	6.00	EACH		\$	

Section: 0004 - DEMOBILIZATION

LINE	BID CODE	ALT	DESCRIPTION	QUANTITY	UNIT	UNIT PRIC	FP	AMOUNT
0140	02569		DEMOBILIZATION	1.00	LS		\$	